

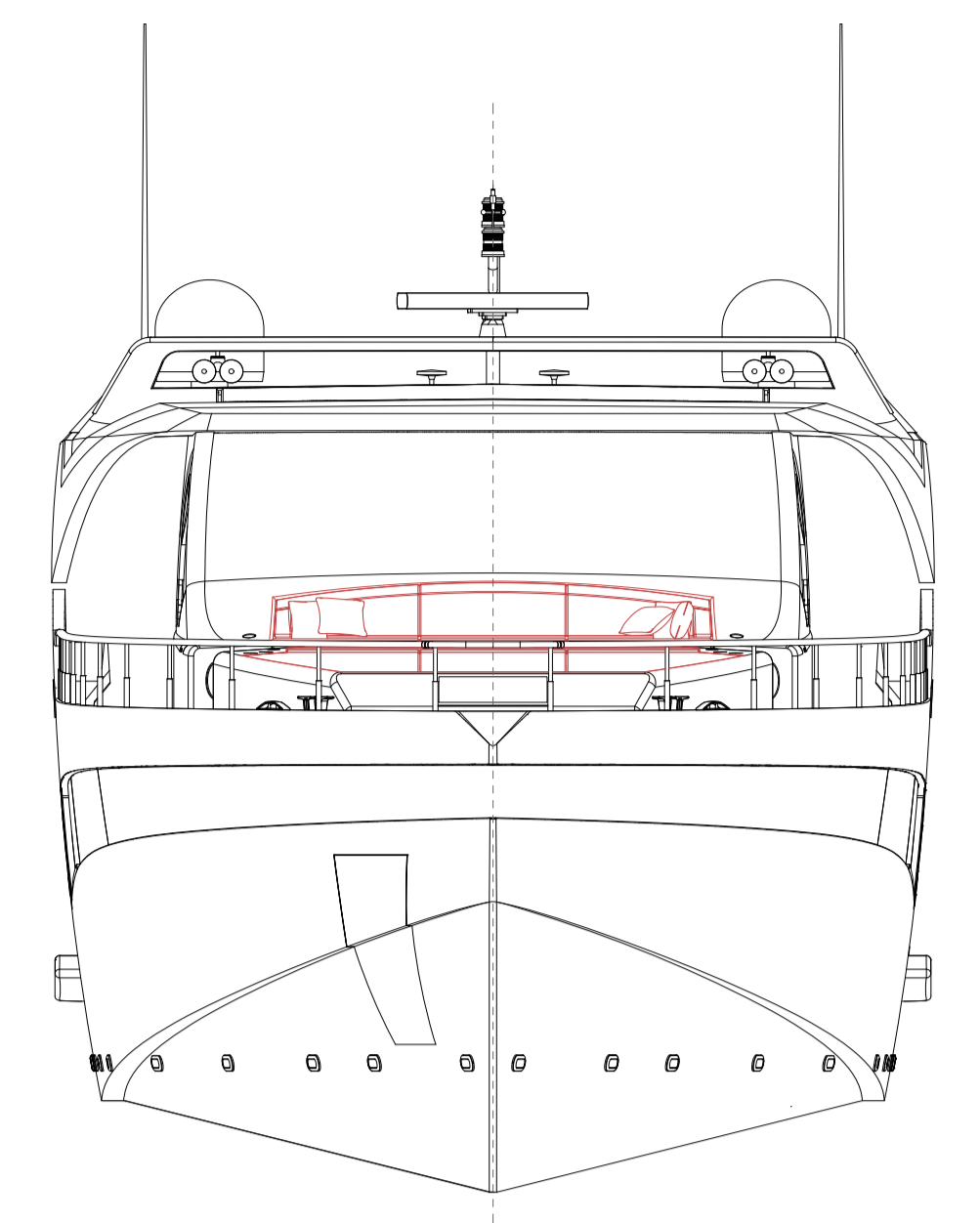

PROFILE

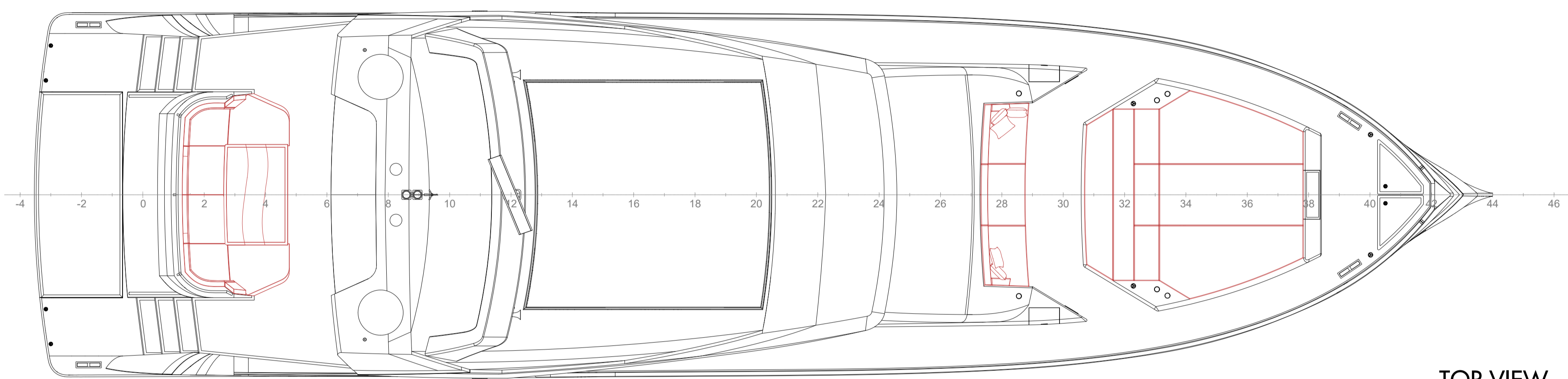

FRONT VIEW



TOP VIEW

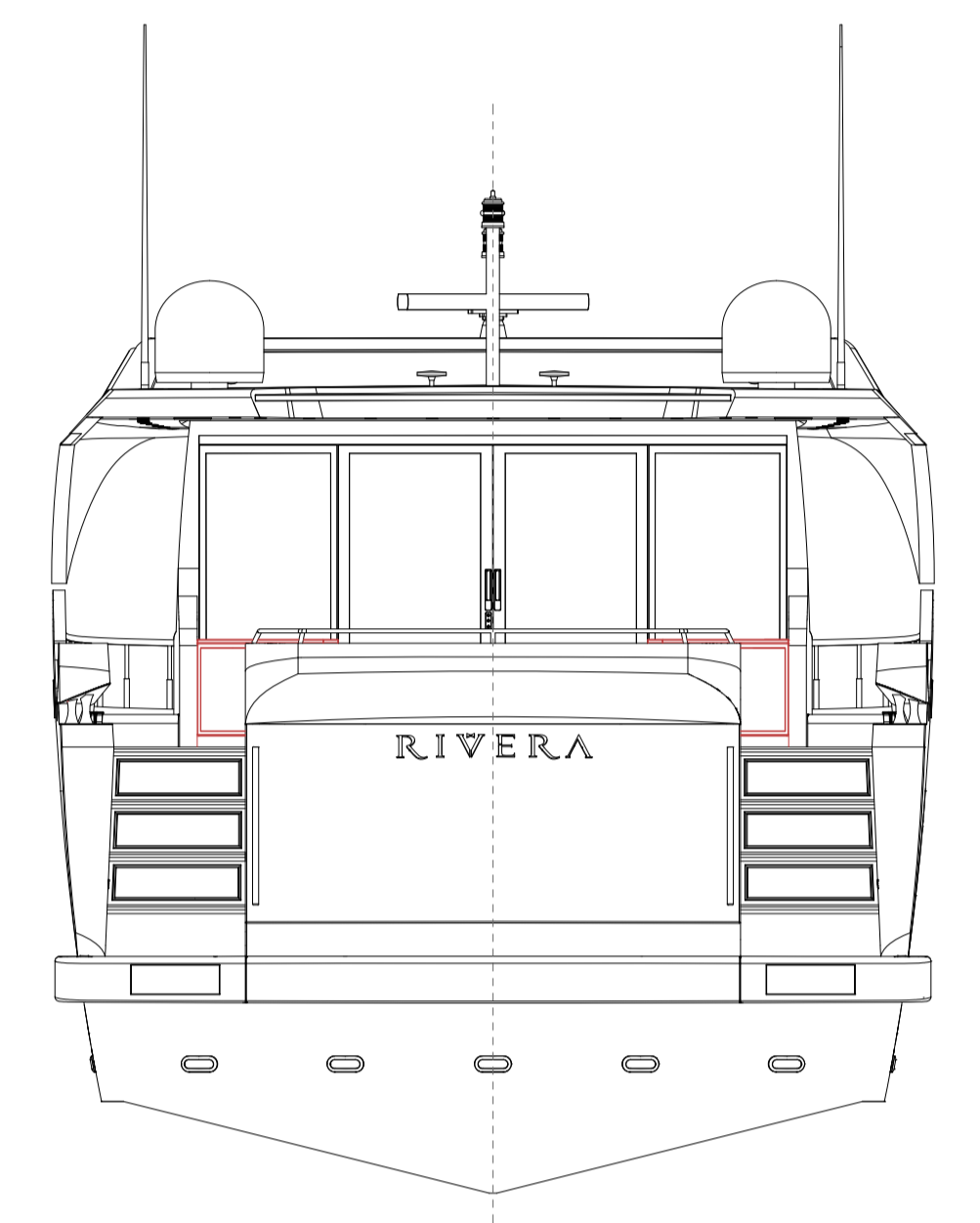

AFT VIEW

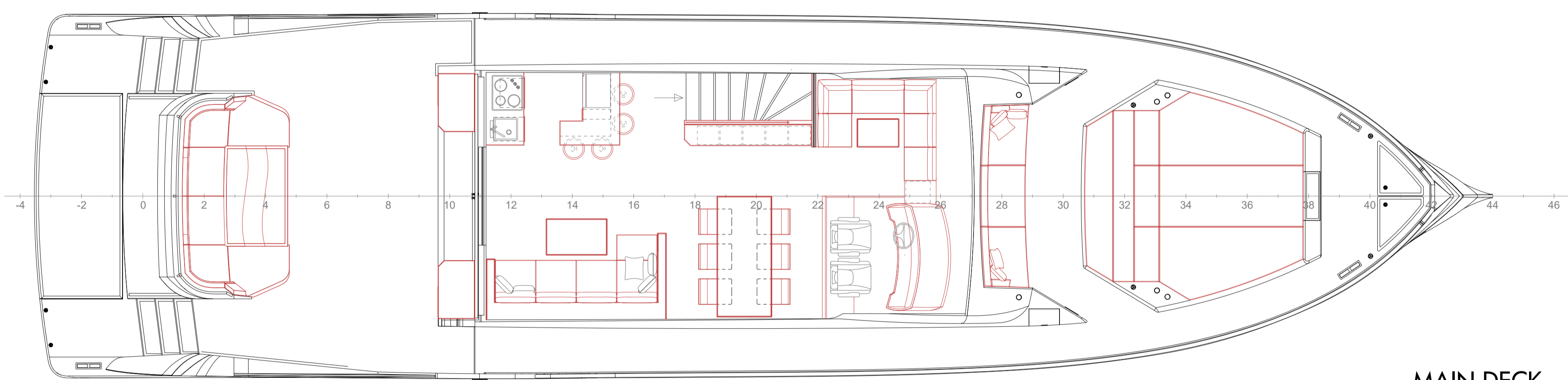

MAIN DECK

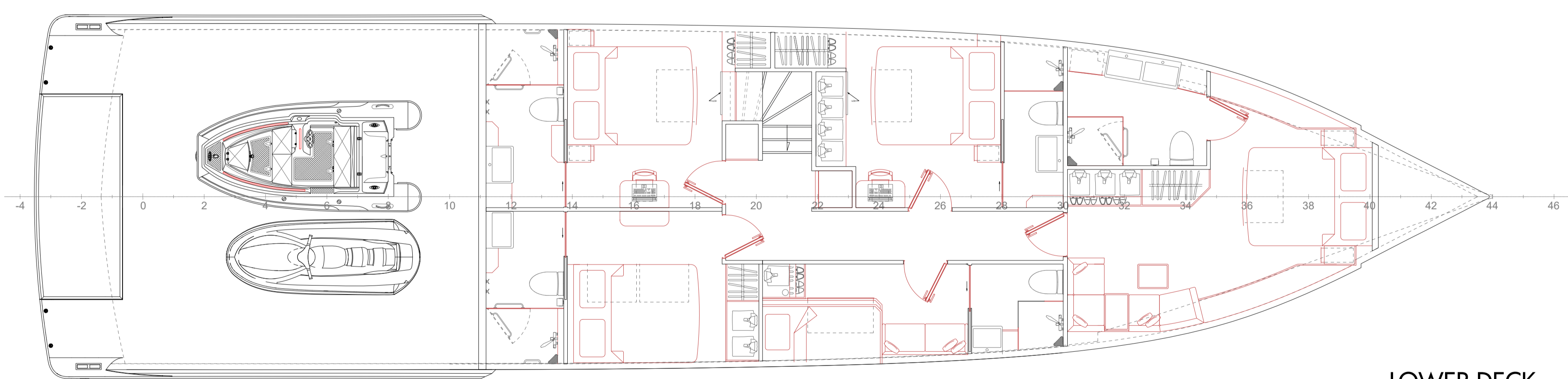

LOWER DECK



**KBY-016-01 RIVERA 780**

MAIN DIMENSIONS	
Length o.a.:	23,80m
Max Beam:	6,00m
Design Depth:	1,00m
Frame Spacing:	0,50m
Fuel capacity:	9000 l
Fresh Water:	2000 l
Engine:	2xVOLVO PENTA D13-900
Engine:	2 x 900 HP
Propulsion system:	IPS 1200 / IPS 3
Maximum speed:	~30 knots
Accommodation:	8 + 2 (crew)

REV.	DATENAME	REVISION TEXT
<b>GENERAL ARRANGEMENT</b>		
DESCRIPTION: M/Y RIVERA 780		PROJECT NO: KBY-016-01
DESIGN BY:	CUSTOMER:	DRAWING NO: 101-100
		REVISION: 8
DRAWN: P. SERVAZ S. BAZNYI	DATE: 2017.10.16	SCALE: 1:50
CHECKED:	PLOTTED:	SHEET: 1 OF 1
		FORMAT: A0